



Compact Remote Air Command™

INSTALLATION INSTRUCTIONS

Congratulations on your purchase of an Air Command kit. This kit was designed to provide inflation control of your air helper springs. This kit will be an asset to your vehicle, meeting nearly all of your air supply needs.

Please take a few minutes to read through the instructions to identify the components and learn how to properly install your Air Command kit.

NOTE:

The Air Command kit can be used with all air helper spring products. If you are installing an air suspension system, do not install the air line tubing to the air springs as stated in the suspension system instruction manual. If you are adding the Air Command kit to an existing air suspension system, you will need to deflate the air springs and remove the air line tubing.

NOTE ON CONNECTING THE AIR LINE TUBING

Cut the air line tubing as squarely as possible. To connect the air line tubing to the fittings, push the tubing into the fittings as far as possible. If for any reason the tubing must be removed, first release the air pressure from the air helper spring. Push the collar towards the body of the fitting and then pull out the tubing. To reassemble, make sure the tubing is cut squarely and push the tubing back into the fitting.

PARTS LIST

KEY-FOB PAIRED UNIT	9465	1
KEY-FOB	9459	1
ECU	9460	1
AIR COMPRESSOR	9377	1
KEY-FOB WIRE HARNESS	9464	1
EXHAUST VALVE	9107	1
SEALED RELAY	9361	1
AIR LINE (18 FT.)		1

HARDWARE PACK (A21-760-2555)

COMPRESSOR TEE	3066	1
1/4" PTC TEE	3025	1
10-32 X 3/4" MACHINE SCREW		5
10-32 X 1" MACHINE SCREW		4
10-32 NYLOCK NUT		9
10-16 X 3/4" SELF TAPPING SCREW		1
3/16" FLAT WASHER		13
1/4" MALE SPADE TERMINAL		2
VELCRO TABS		4
NYLON TIE		15
THERMAL SLEEVE		2

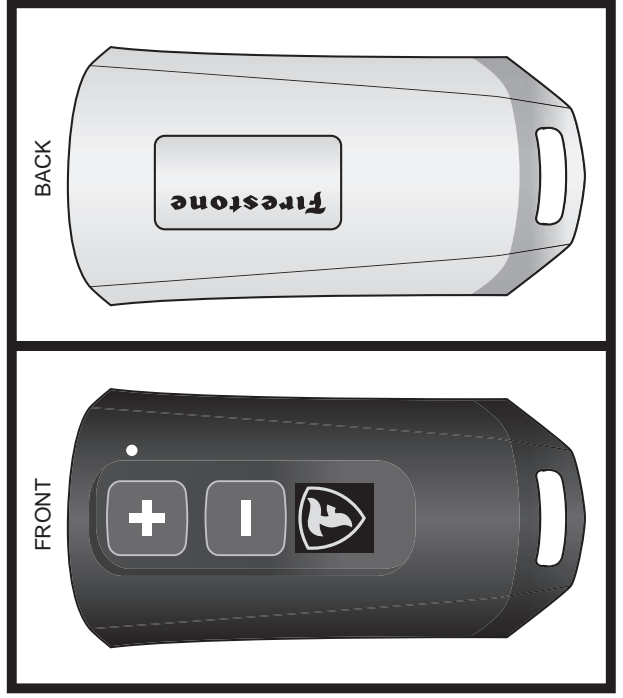
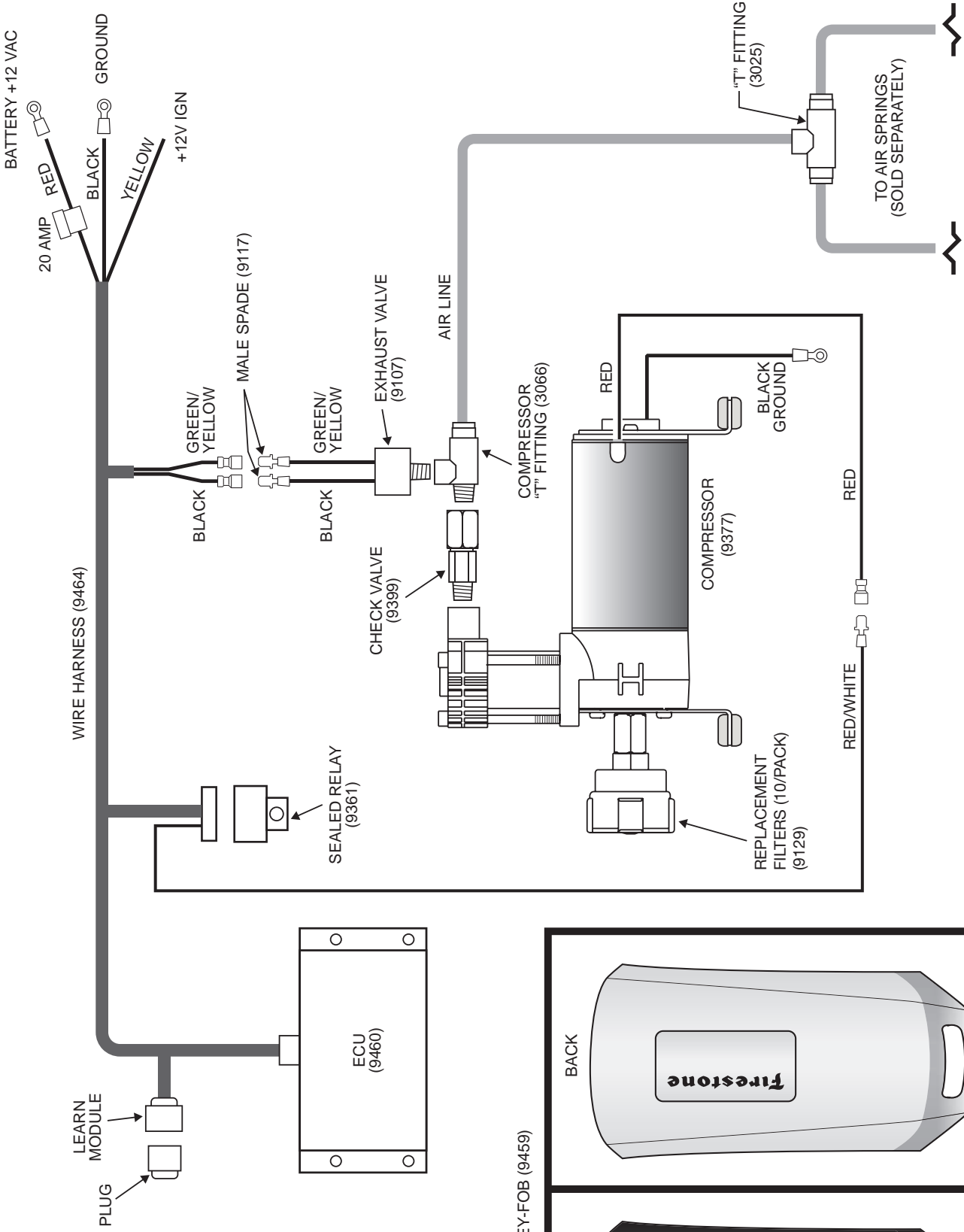

STEP 1 — MOUNT THE COMPRESSOR AND EXHAUST VALVE

Disconnect the negative battery cable. Select a convenient location to mount the compressor (9377). This location should be protected from airborne debris and moisture. The mounting surface should be rigid to support the compressor. The compressor is oil-less and can be mounted in any orientation necessary for installation. Make sure that the wire harness will reach from the compressor to the anticipated location of the ECU. Install the check valve and compressor tee fitting into the threaded output on the compressor head, **see Figure "A"**. Tighten the fitting sufficiently to engage at least two threads with the pre-applied thread sealant. **DO NOT OVERTIGHTEN THE FITTING.** Crimp the two 1/4" male spade terminals to the black and green/yellow wires of the exhaust valve using a multi-tool or appropriate crimper. Install the exhaust valve (9107) into the compressor tee fitting. Mark the four compressor mounting holes using the compressor as a template and a center punch, then drill four 7/32" holes. Mount the compressor using the supplied 10-32 x 1" machine screws, 10-32 Nylock nuts and 3/16" washers. **See Figure "B"**.

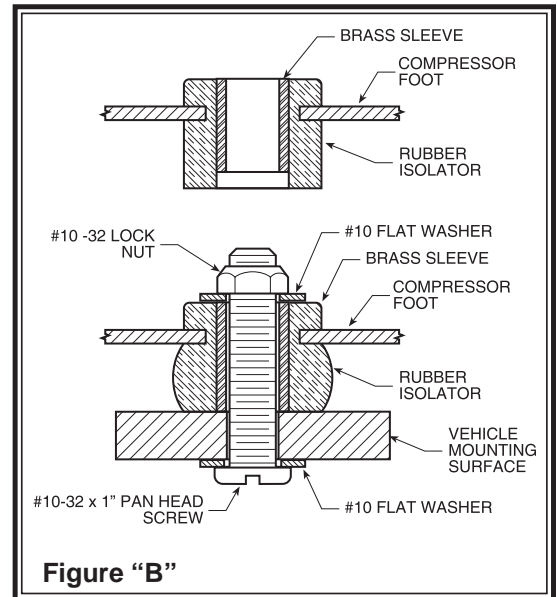

STEP 2 — MOUNT THE ECU

Select the ECU (9460) from your kit. Mark the four mounting holes using the ECU as a template. Center punch, then drill four, 7/32" holes. The ECU can be mounted using only two holes, one on either side, if necessary. Mount the ECU using the supplied 10-32 x 3/4" machine screws, 10-32 Nylock nuts, and 3/16" washers.

STEP 3 — WIRE THE ECU AND COMPRESSOR

Plug the 14-pin connector from the wire harness (9464) into the back of the ECU. Ground the compressor (black wire with ring terminal) to a suitable location on the chassis. Attach the red/white wire with the spade terminal from the relay to the red wire of the compressor. Attach the black wire with the female spade terminal to the black wire of the exhaust valve (9107). Repeat for the green/yellow wires. Attach the sealed relay to the wire harness and mount to the chassis. Route the wire harness into the engine compartment. Attach the yellow wire to a +12VDC ignition-activated source. Attach the black wire to the negative battery terminal. Attach the red wire with in-line fuse to the positive battery terminal. **See Figure "A"**.

STEP 4 — MOUNT THE KEY-FOB

The key-fob can be mounted in the cabin using the four Velcro pads. Properly clean the mounting surfaces to remove dirt and oils. **NOTE: The key-fob should not be left outside of the vehicle if not in operation. Keep the key-fob away from moisture.**

STEP 5 — ROUTE THE AIR LINE

Cut the air tubing as squarely as possible to avoid leaks. Avoid hot surfaces and sharp edges. Cut away about 1/4" from the end of the air tubing if trying to reinstall into an air fitting to avoid leaks.

INSTALL: Press the air tubing into the push-to-connect fitting until it bottoms out. Lightly pull back on the air tubing to ensure the fitting has properly secured the air tubing.

UNINSTALL: MAKE SURE THERE IS NO AIR IN THE AIR TUBING BEFORE ATTEMPTING! Press towards the fitting body on the collar (use a 1/4" open-end wrench if needed). Push the air tubing towards the fitting while pressing on the collar and then pull back on the tubing. The air tubing should come out fairly easily. If it does not, **DO NOT** force the air tubing. Doing so will damage the fitting and may cause leaks.

Cut a length of air-line to place into the compressor tee fitting and route back to the air springs. Insert the airline into the tee fitting, routing each branch out to the air springs.

NOTE: Water pulled through the compressor air filter will void the compressor warranty. DO NOT SUBMERGE.

STEP 6 — USING THE KEY-FOB

With the Air Command kit and the air springs installed, you are ready to test the system. Re-attach the negative battery cable. Turn on the vehicle's ignition.

Press the "+" button to activate the compressor. This will increase the pressure of the air springs until the desired height is achieved. Press the "-" button on the key-fob to activate the exhaust valve. This will remove the pressure in the system.

REPLACING THE BATTERY

The key-fob uses a lithium coin-cell battery (size: CR2032). Remove the two Phillips head screws from the back of the key-fob. Carefully, separate the two halves. Gently remove the old battery and insert the new battery in the holder, with the positive (+) side facing up. Reassemble the two halves, making sure all of the components stayed in place. Secure the two halves using the same screws that were removed. **DO NOT OVERTIGHTEN!**

STEP 7 — CHECK THE SYSTEM

Inflate the air springs to 70 psi or the max air spring pressure, which ever is less, and check the fittings for air leaks with a solution of soap and water. If a leak is detected at a tubing connection, check to make sure that the tube is cut as squarely as possible and that it is pushed completely into the fitting. The tubing can easily be removed from the fitting by first releasing the pressure from the air spring, then by pushing the collar towards the body of the fitting and holding, then pulling the tube out.

